

NOTE: HYDRO-BLEND VERTICAL MOUNT SYSTEM PART NUMBERS CONTAIN THE ABBREVIATION "VM"
 THIS ABBREVIATION DENOTES THE SYSTEMS MOUNTING ORIENTATION (SEE PACKING SLIP FOR PUMP NUMBER)

VM = VERTICAL MOUNT - DESIGNED TO MOUNT ON A VERTICAL SURFACE (I.E. A WALL)

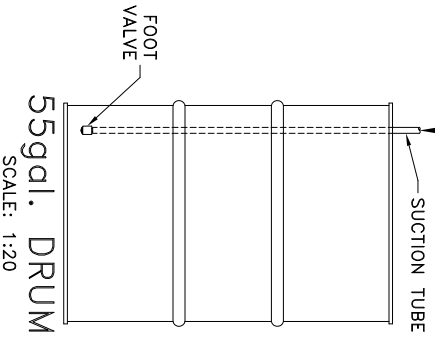
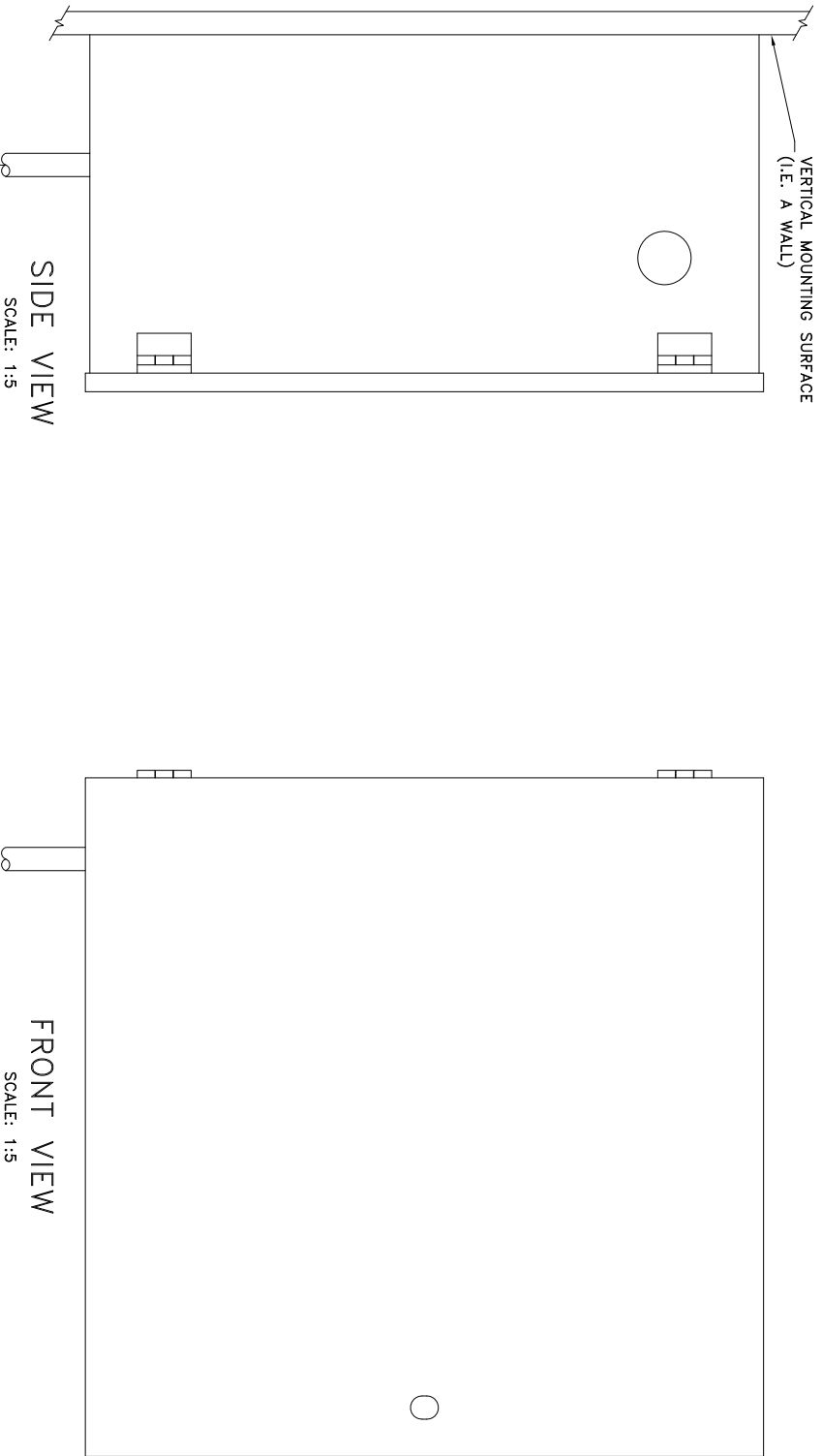

SCALE:	SHEET:	DATE:
NOTED	1 of 1	06/04/07
DRAWN BY:	CHECKED BY:	
SC	DK	
SERIES:	DESCRIPTION:	
REVISION:	REvised BY:	DATE:
	SC	03/24/08

C:\AUTOCAD\CROWN Paper\Wall Mounting -Instructions\System-VM-Mounting-Instructions.dwg



5301 SAWYER AVENUE BOISE, ID 83714
 PHONE: (208) 375-5000 www.hydroblend.com

**MOUNTING INSTRUCTIONS
 SYSTEM-VERTICAL MOUNT**

- REVISION:
- (A) CHANGED ALL JACO FITTINGS TO SST COMPRESSION FITTINGS, AS PER ECOLABS REQUEST, 02/09/07.
 - (B) PART NO. WAS 0161-6025/10-DI-HDPE-VM ECO. CHANGE REFLECTS UPGRADE TO APPLICATION SPECIFIC SEAL PACKAGE, 09/16/08.
 - (B1) SUCTION TUBE MATERIAL CHANGED TO TYGON, 09/16/08.
 - (B2) INJECTION TUBE MATERIAL CHANGED TO TEFLON, 09/16/08.

PART NO.	DESCRIPTION	QTY.
274-5	Tee - 1/2 Socket x 1/2 Socket x 1/2 FNPT - Sch 80 PVC	2
275-5	Elbow - 1/2 FNPT x 1/2 Socket - Sch 80 PVC	1
276-3	Nipple, Toe - 1/2 MNPT - (Threaded One End) - 3-1/2 Long - Sch 80 PVC	1
276-4	Nipple - 1/2 Dia. - (No Threads) - 2-5/8 Long - Sch 80 PVC	2
278	Barb Fitting - 90 Degree - 3/4 MGH x 1/2 HB - Polypro	1
280	Clamp, Hose - SAE #8 - SST	2
281B	Bracket, Mounting - Mixing Chamber/Water Filter	1
282-500	Regulator, Water Pressure - 1/2 FNPT - 1/4 FNPT Gauge Port - 10-125PSI	1
283	Gauge - 1/4 MNPT - 100PSI	1
293	Spring - Hostalloy C-276	1
536-K	Poppet - Outlet Fitting - Kynar	1
571	Jet, Mixing Chamber - Sch 80 PVC	1
593	Spacer - Acetel	4
655	Retainer, Poppet - (Tee) - 20% Glass Filled Polypro	1
881	Outlet Fitting - 1/4-18 FNPT - (Used With 881A Adapter) - 316 SST	1
881A	Adapter - 3/8-18 FNPT - (Used With 881 Outlet Fitting) - SST	1
881AS	Screw, Set - 8-32 x 3/16 - Pilot Point - 18-8 SST	2
0161-ENCLOSURE	Enclosure - 18.0 x 18.0 x 9.500 - SST	1
2052SST	Female Elbow - 5/8 Tube OD - 1/2 FNPT - SST	2
2071SST	Male Elbow - 1/4 Tube OD - 1/4 MNPT - SST	1
2081SST	Female Connector - 1/4 Tube OD - 1/4 FNPT - SST	1
2082SST	Female Connector - 5/8 Tube OD - 1/2 FNPT - SST	1
2561M-2	Housing, Mixing Chamber - 1/2 FNPT - (Top Hole - Machined)	1
2591SST	Tubing Insert - 5/8 OD x 1/2 ID Tube - SST	8
2603	Valve, Ball - 1/2 FNPT - (3 Way) - Brass	1
2681SST	Tubing Insert - 1/4 OD x 1/8 ID Tube - SST	4
6025/10-DI-HDPE-ARV,VM ECO	Hydro-Blend Proportioner	1
9222	Stainless Steel Bulkhead Fitting Assembly - 3/4 FNPT	2
LOOK	Lock & Key - For SST Enclosures - Part Not Shown On Print	1

SHIPPING INFORMATION:
 SYSTEM BOX = 001-4
 FOAM PACKAGED (25 x 25 x 20)
 MODEL NO. SERIAL NO. STICKER
 LOWER LEFT HAND CORNER OF BOX

WEIGHTED STRAINER NO. = 9309
 SUCTION TUBE NO. = 263-TYCON
 WEIGHTED STRAINER NO. = 9307
 SUCTION TUBE = 264-TYCON

OPERATING MANUAL = NONE
 PUMP SCHEMATIC = NONE

SCALE: NTS 2 of 6 SHEET: 11/11/05 DATE: 06/19/13

FORM BR: SC CHECKED BY: DK

7 GPM DESCRIPTION: Ecolab System

REGON: B2 REGED BY: SC

5301 SAWYER AVENUE BOISE, ID 83714
 PHONE: (208) 375-5000 www.hydroblend.com

0161-6025/10-DI-HDPE-ARV,VM ECO

C:\Autocad\pump\Systems\ecolab\0161-6025-10-DI-HDPE-ARV,VM ECO.dwg

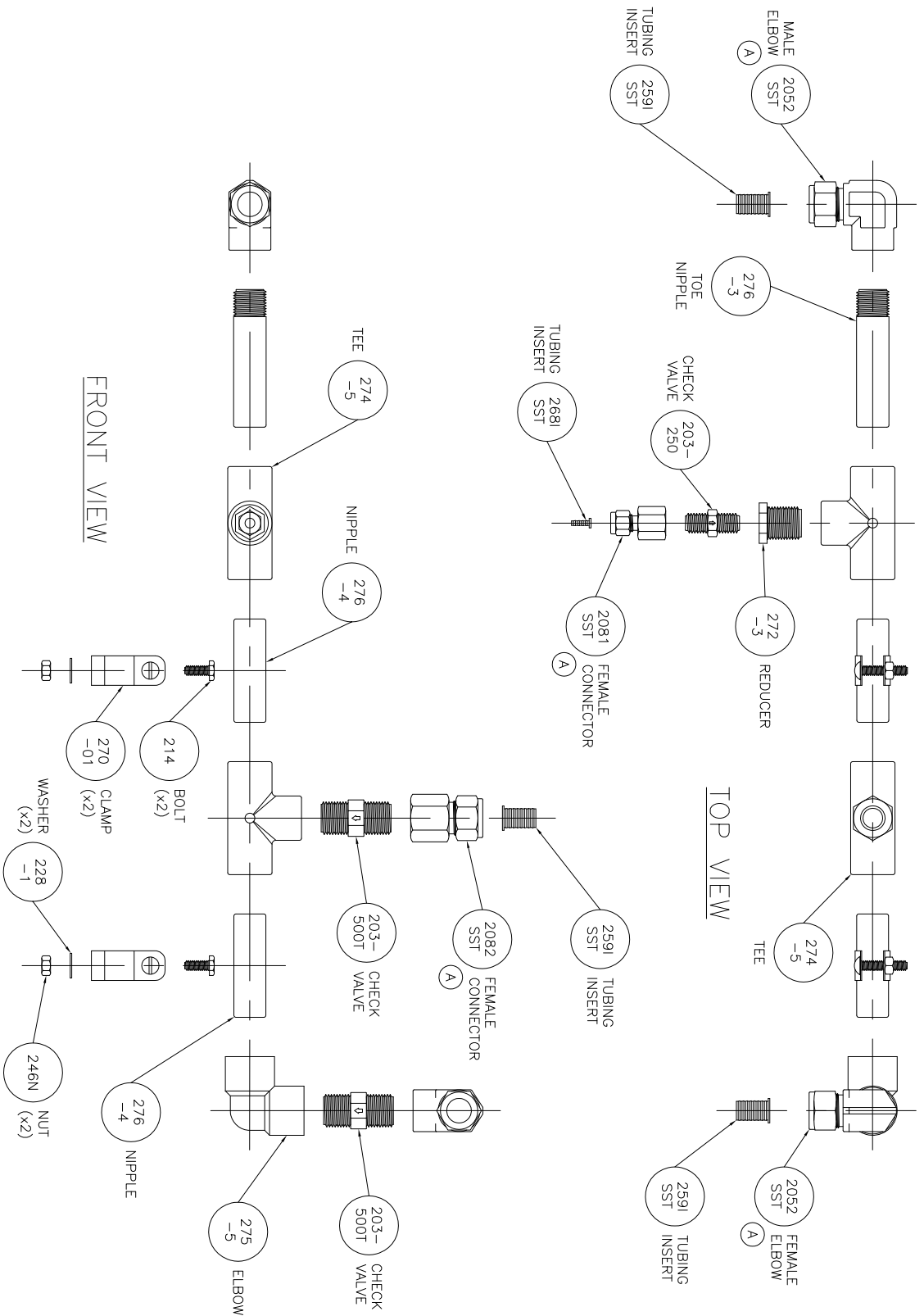

SCALE: 1:4	SHEET: 3 of 6	DATE: 11/11/05	
DRAWN BY: SC	CHECKED BY: DK	DESCRIPTION: Ecolab System	
SERIES: 7 GPM	DATE: 06/19/13	PHONE: (208) 375-5000 www.hydroblend.com	
REVISION: B2	REVISION BY: SC	PART NUMBER: 0161-ECO ASSEMBLY 1	

C:\Autocad\grom\Systems\ecolab\0161-ECO.dwg - 06/25/13 - 10:10:46 AM ECO.dwg

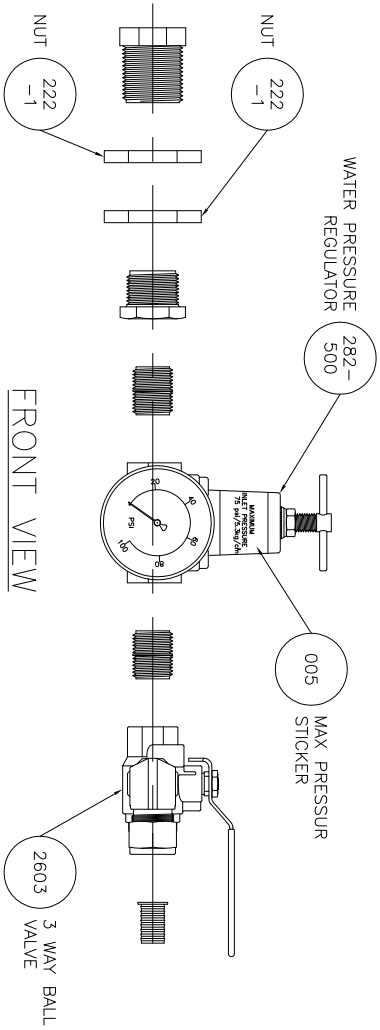
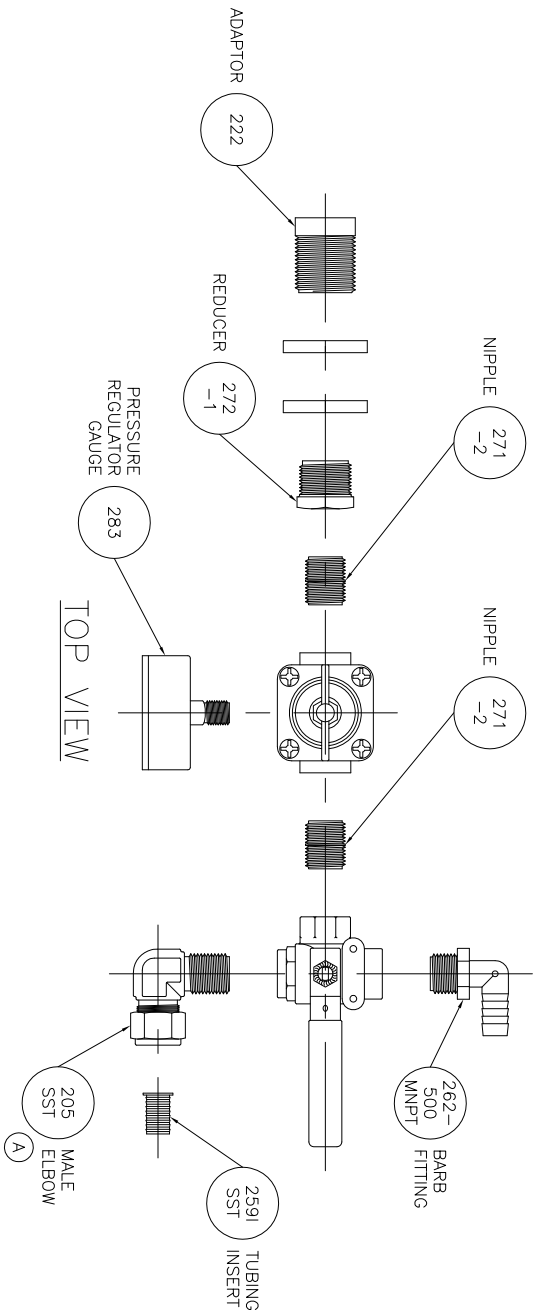

SCALE:	1:4	SHEET:	4 of 6	DATE:	11/11/05
DRAWN BY:	SC	CHECKED BY:	DK		
SERIES:	7 GPM	DESCRIPTION:	Ecolab System		
REVISION:	B2	REvised BY:	SC	DATE:	06/19/13

C:\AUTOCAD\GROWM\System\Ecobal\10161-6025-10-D-10PE-V.M 603.dwg



HYDRO-BLEND

5301 SAWYER AVENUE BOISE, ID 83714
 PHONE: (208) 375-5000 www.hydroblend.com

0161-ECO
ASSEMBLY 2

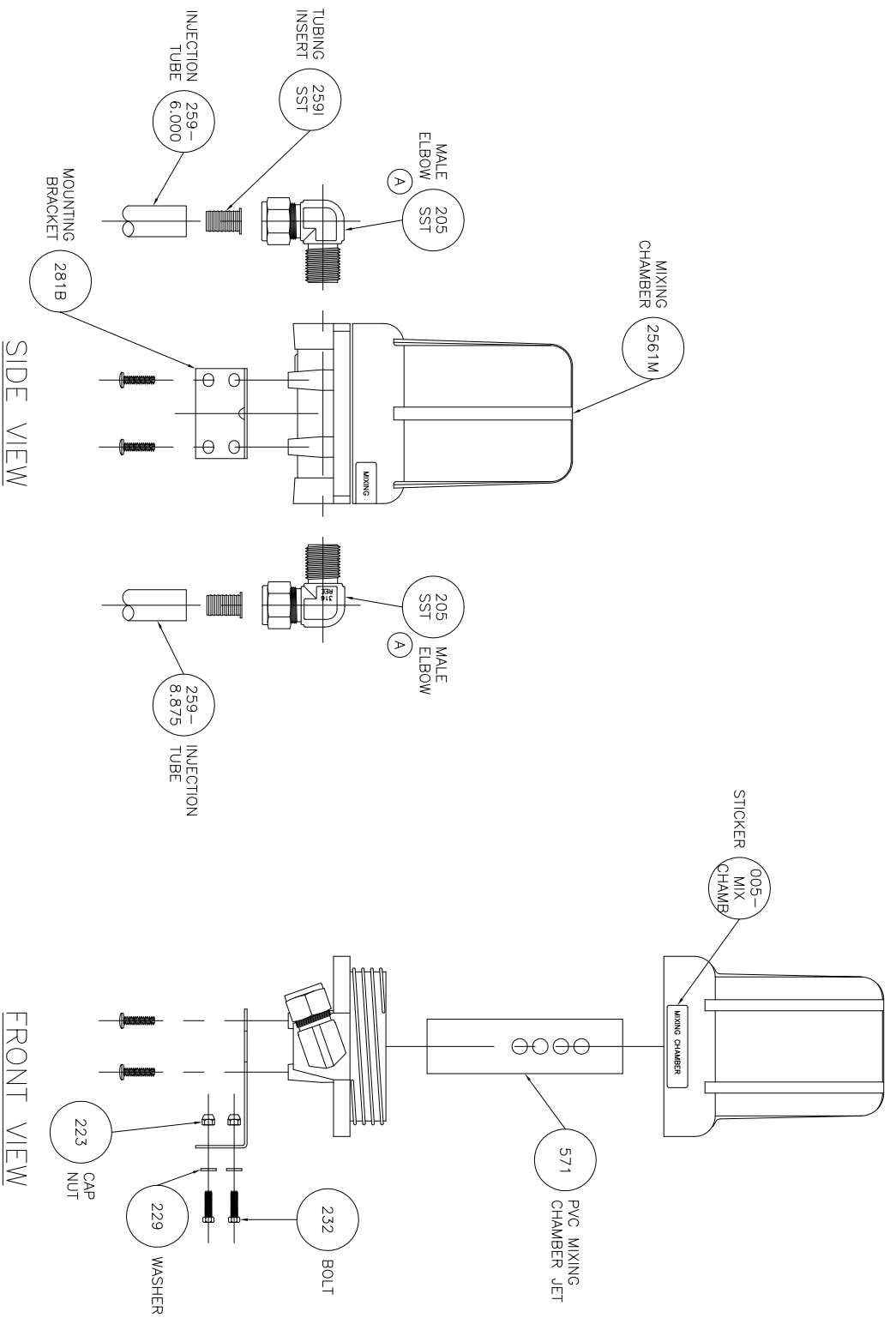

SCALE:	1:4	SHEET:	5 of 6	DATE:	11/11/05	C:\AUTOCAD\BROWN\System\Layout\10161-6025-10-D-10PE-V.M ECO.dwg	
DRAWN BY:	SC	CHECKED BY:	DK	DESCRIPTION:			
SERIES:	7 GPM	Ecolab System		PART NUMBER:			
REVISION:	B2	REvised BY:	SC	DATE:	12/03/08	ASSEMBLY 3	



5301 SAWYER AVENUE BOISE, ID 83714
 PHONE: (208) 375-5000 www.hydroblend.com

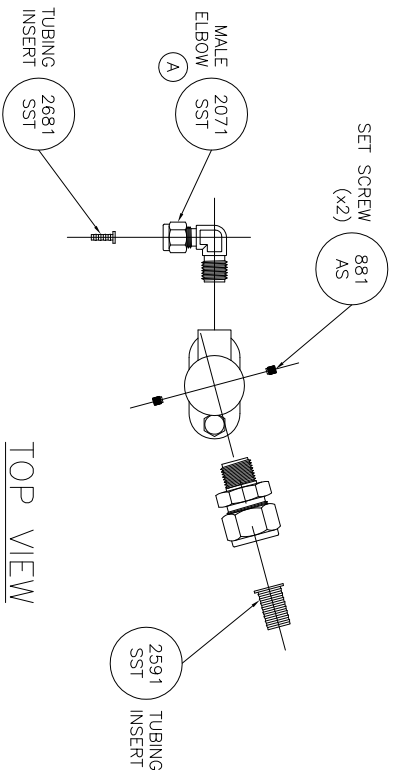

TOP VIEW

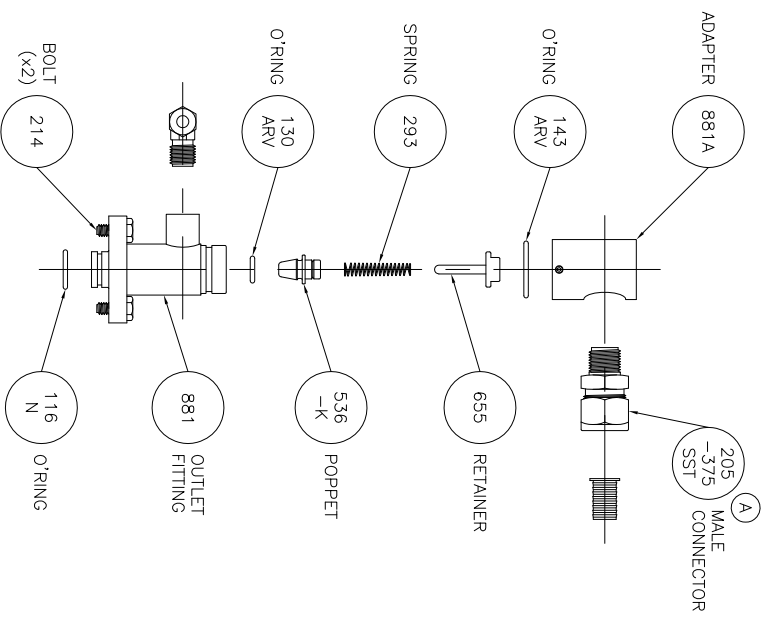

FRONT VIEW

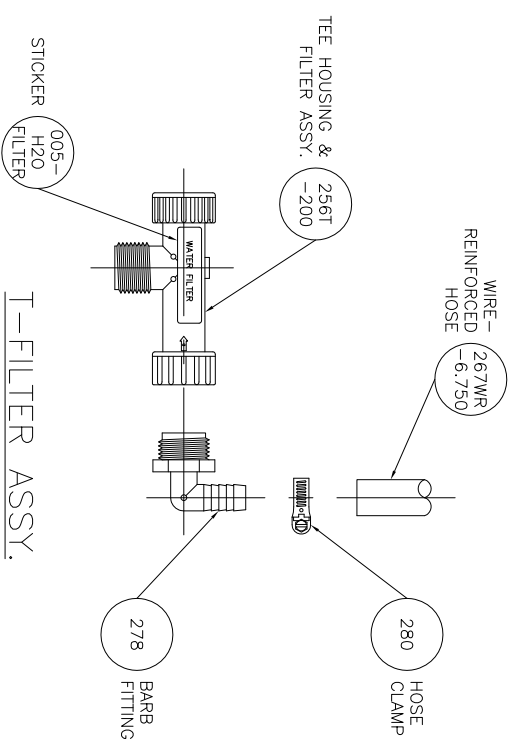

T-FILTER ASSY.

SCALE:	1:4	SHEET:	6 of 6	DATE:	11/11/05
DRAWN BY:	SC	CHECKED BY:	DK	DESCRIPTION:	
SERIES:	7 GPM	REVISION:	B2	DATE:	06/19/13
Ecolab System			5301 SAWYER AVENUE BOISE, ID 83714		
PART NUMBER:			PHONE: (208) 375-5000 www.hydroblend.com		
REVISION:			0161-ECO		
ASSEMBLY			4		

C:\AUTOCAD\SYSTEMS\Systems\Ecolab\10161-ECO25-10-01-10PE-VMM ECO.dwg



SHIPPED 1st PRODUCTION ORDER 11/11/05
 REVISION:

- (A) CHANGED ALL JACO FITTINGS TO SST COMPRESSION FITTINGS, AS PER ECO LABS REQUEST, 02/09/07.
- (B) ADDED O'RING COUNTER BORE TO TOP OF ENDPLATE, 10/17/07.
- (B1) WAS 112N O'RING, 10/17/07.
- (C) PART NO. WAS 6025/10-DI-HDPE-V-HM ECO. CHANGE REFLECTS UPGRADE TO APPLICATION SPECIFIC SEAL PACKAGE, 09/16/08.
- (C1) SUCTION TUBE MATERIAL CHANGED TO TYGON, 09/16/08.
- (D) LOWER VALVE SCREWS CHANGED TO COMPRESSION FITTINGS AS PER ECO LABS REQUEST, 11/14/08.

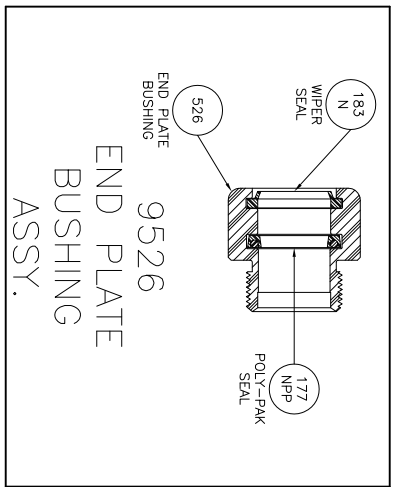

DETAIL A
 SCALE: 1:2

SHIPPING INFORMATION:
 LARGE BOX = 001-2
 TOP INSERT = 001-2A
 MIDDLE INSERT = 001-2B
 BOTTOM INSERT = 001-2C

WEIGHTED STRAINER NO. = 2.5 OZ.
 SUCTION TUBE NO. = 9309
 TYGON TUBING INSERT NO. = 2631K

WEIGHTED STRAINER NO. = 1.07
 SUCTION TUBE NO. = 264-1
 TYGON TUBING INSERT NO. = 2641K

OPERATING MANUAL = NONE
 PUMP SCHEMATIC = NONE

SCALE:	NOTED	SHEET:	2 of 2	DATE:	06/03/05
DESIGNATION:	SC	CHECKED BY:	DK	DATE:	
REVISION:	D	REMOVED BY:	SC	DATE:	07/09/12
DESCRIPTION:	7 GPM	DATE:	Dudl		
SERIES:		DESCRIPTION:	2.5oz./1oz.		

5301 SAWYER AVENUE BOISE, ID 83714
 PHONE: (208) 375-5000 www.hydroblend.com

6025/10-DI-
 HDPE-ARV, HM ECO